

## Joining to Different Materials

In many site situations you will encounter different materials. Such situations mean that you will be faced with issues connecting materials of differing internal and external diameters as detailed in table 1. The details contained within this Technical Bulletin provide a useful reference for connecting from different pipe materials products to Terrain Drainage products.

**Table 1: Pipe Materials and Diameters**

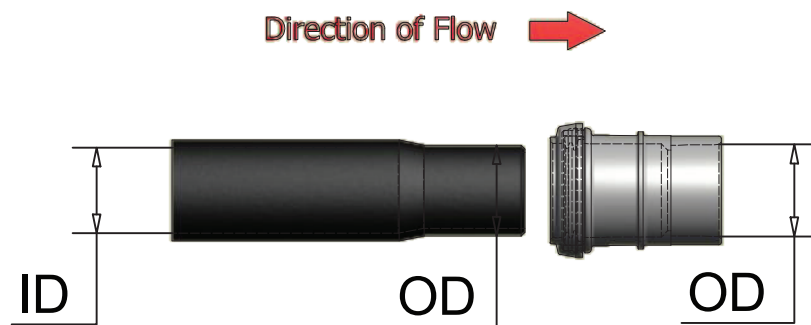

OD		1 1/4"	1 1/2"	2"	3"	4"	6"
	PVC-u	36mm	43mm	56mm	82mm	110mm	160mm
	PP	35mm	41mm	54mm			
	FUZE (HDPE)	40mm	50mm	56mm	90mm	110mm	160mm
	dB12	40mm		50mm		110mm	160mm
	Silere			58mm		110mm	160mm
	Iron	42mm	47.8mm	60mm			
	Copper	35mm	42mm	54mm		108mm	
	Clay					100mm	
	Vulcathene		48mm	60mm	89mm	114mm	
	Cast Iron					112mm	
ID		1 1/4"	1 1/2"	2"	3"	4"	6"
	PVC-u	32mm	39mm	52mm	76mm	104mm	154mm
	PP	31mm	37mm	50mm			
	FUZE (HDPE)	34mm	44mm	50mm	83mm	101mm	148mm
	dB12	36mm		46mm		104mm	153mm
	Silere			50mm		99mm	148.8mm
	Iron	32mm	38mm	50mm			
	Copper	32mm	39mm	51mm		104mm	
	Clay					76mm	
	Vulcathene		38mm	51mm	76mm	102mm	
	Cast Iron					98mm	

# TERRAIN

Technical Bulletin No.1 (2012)

## Product Information

### KEY FEATURES:

Specific products for adapting in the direction of flow.

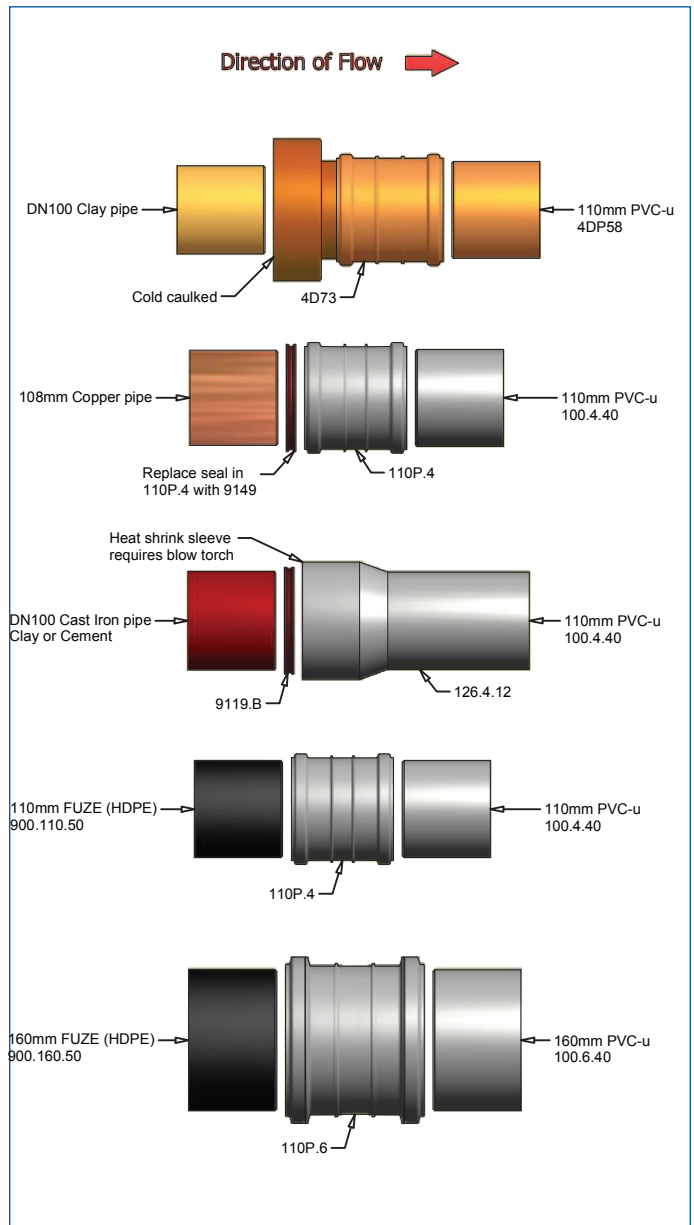
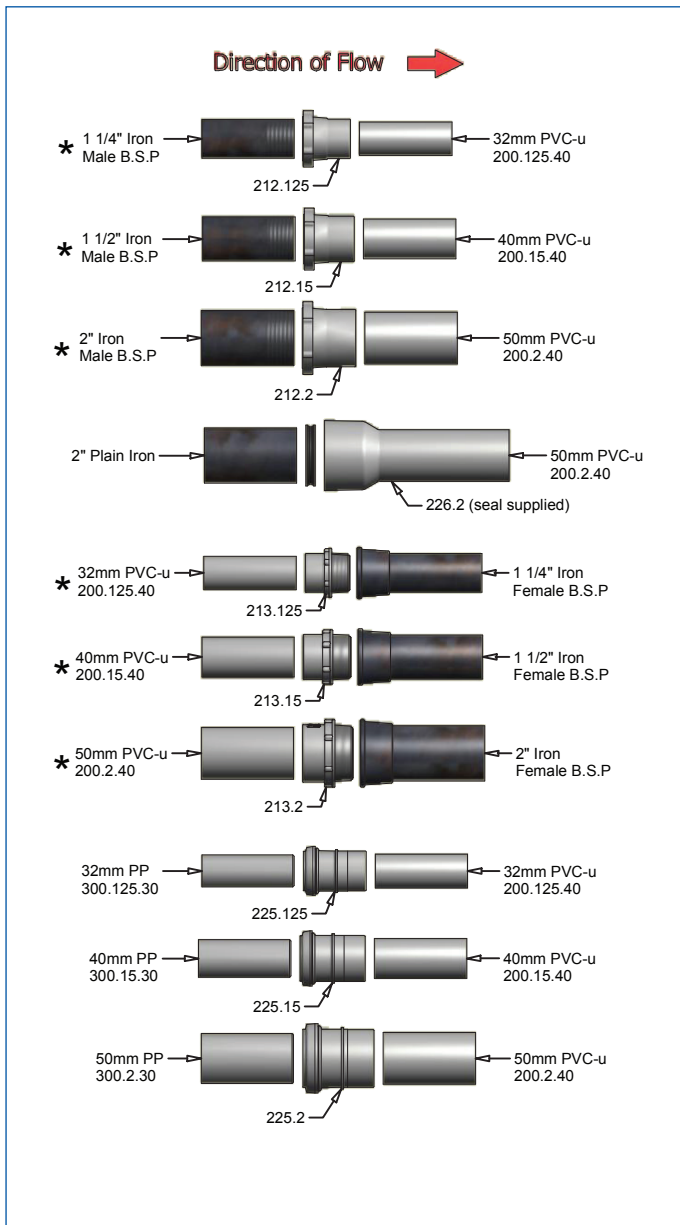

Note: Pipes to be chamfered and lubricated when being used with ring seal, use 9136.50 Silicone grease.

\* Use PTFE on threads.

#### References

1. Terrain Soil and Waste Product Installation
2. BSEN12056 Gravity drainage systems inside buildings Sanitary pipework, layout and calculation.

If in doubt ask - Technical 01622 795200

T: 01622 795200

E: [commercialenquiries@polypipe.com](mailto:commercialenquiries@polypipe.com)

 **Polypipe**

[www.polypipe.com/building-services](http://www.polypipe.com/building-services)

# TERRAIN

Technical Bulletin No.1 (2012)

## Product Information

### KEY FEATURES:

Specific products for adapting in the direction of flow.

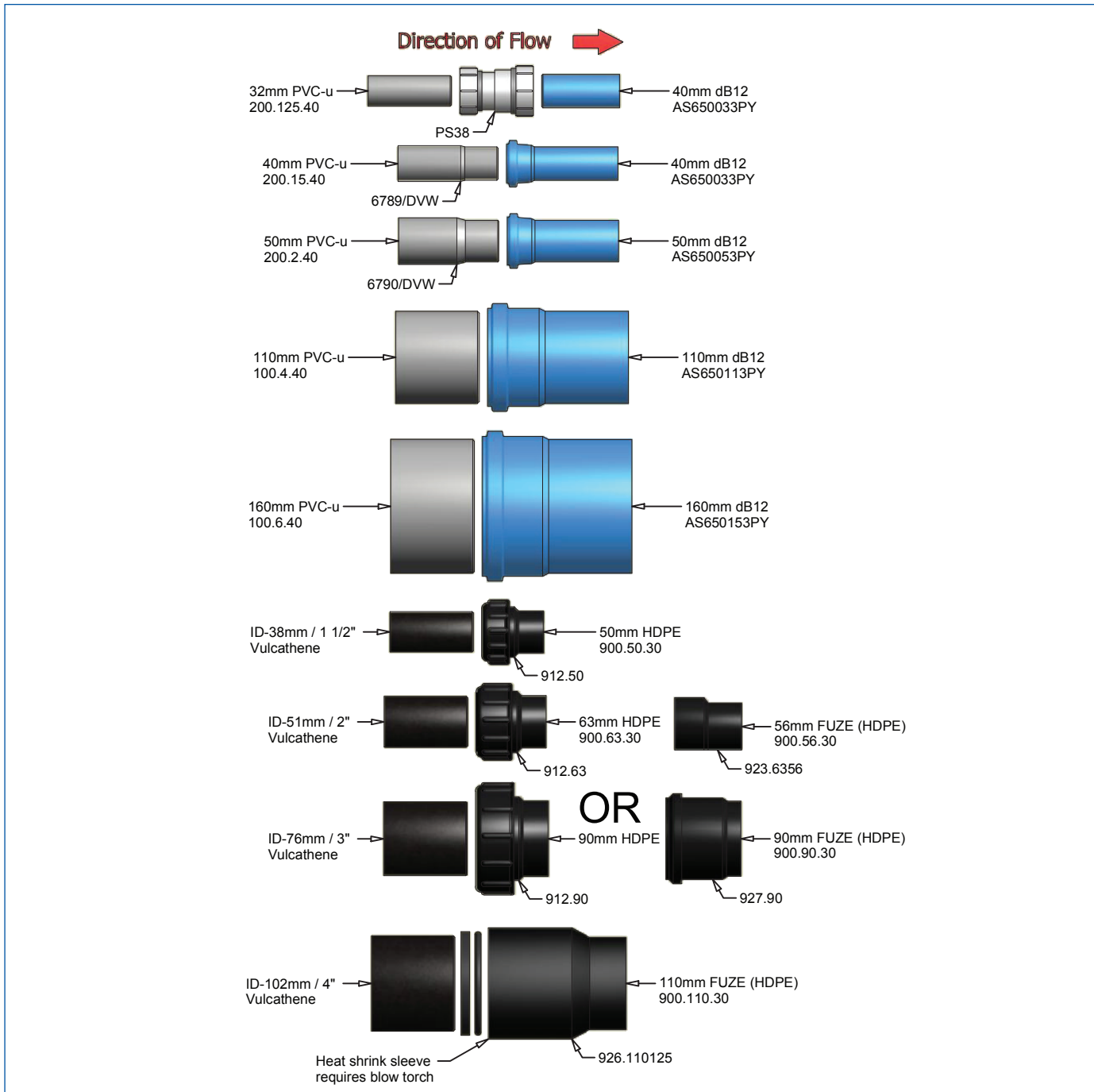

Note: Pipes to be chamfered and lubricated when being used with ring seal, use 9136.50 Silicone grease.

\* Use PTFE on threads.

#### References

1. Terrain Soil and Waste Product Installation
2. BSEN12056 Gravity drainage systems inside buildings Sanitary pipework, layout and calculation.

If in doubt ask - Technical 01622 795200

T: 01622 795200

E: [commercialenquiries@polypipe.com](mailto:commercialenquiries@polypipe.com)

Polypipe

[www.polypipe.com/building-services](http://www.polypipe.com/building-services)

# TERRAIN

Technical Bulletin No.1 (2012)

## Product Information

### KEY FEATURES:

Specific products for adapting in the direction of flow.

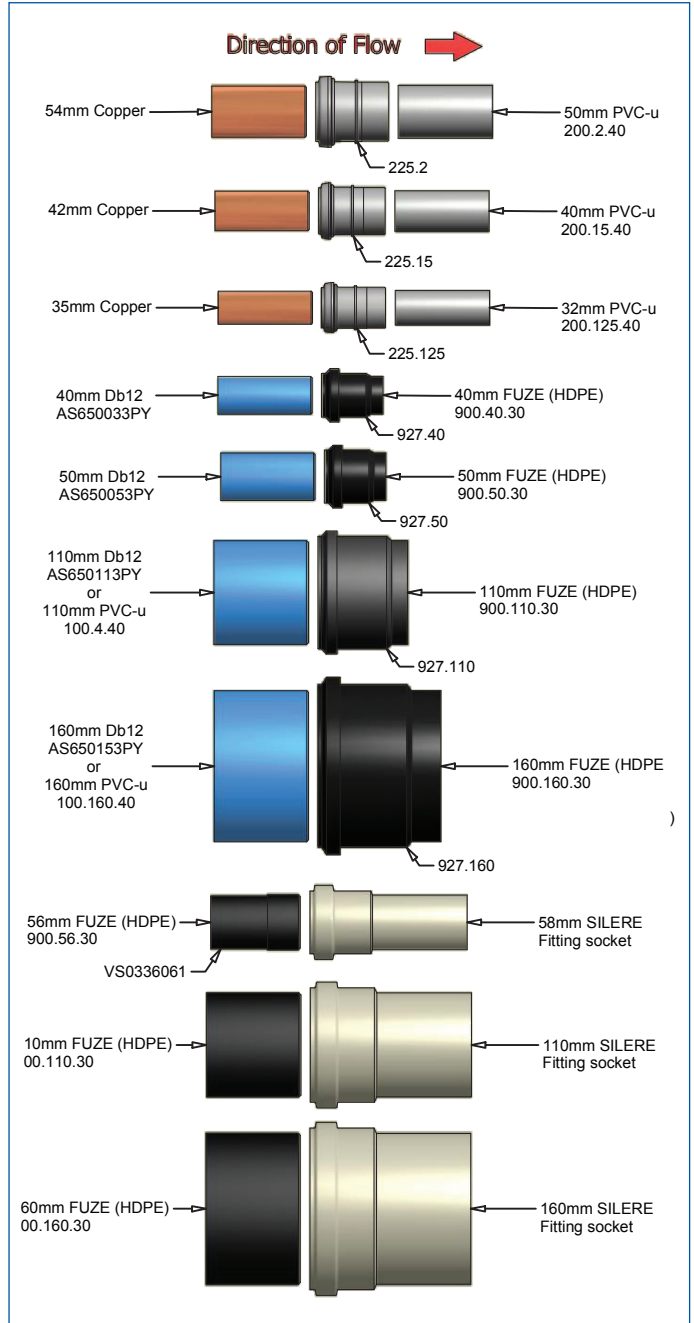
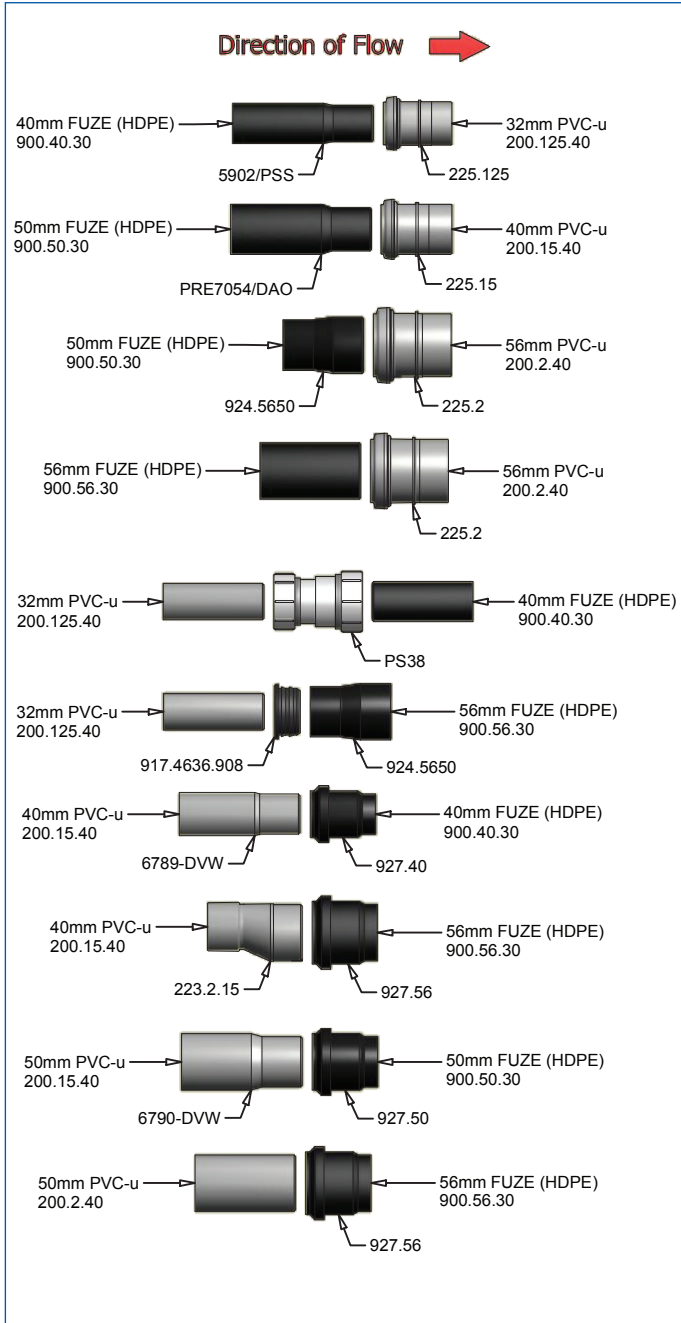

Note: Pipes to be chamfered and lubricated when being used with ring seal, use 9136.50 Silicone grease.

\* Use PTFE on threads.

#### References

1. Terrain Soil and Waste Product Installation
2. BSEN12056 Gravity drainage systems inside buildings Sanitary pipework, layout and calculation.

If in doubt ask - Technical 01622 795200

T: 01622 795200

E: [commercialenquiries@polypipe.com](mailto:commercialenquiries@polypipe.com)



[www.polypipe.com/building-services](http://www.polypipe.com/building-services)