



## Polypipe Building Products Ltd

Broomhouse Lane  
Edlington  
Doncaster  
South Yorkshire DN12 1ES  
Tel: 01709 770000 Fax: 01709 770001

**Agrément  
Certificate  
No 02/3923**

Designated by Government  
to issue  
European Technical  
Approvals

## POLYSEWER GRAVITY SEWER SYSTEM

Système d'égouts  
Kanalisationssystem

# Product



• THIS CERTIFICATE RELATES TO THE POLYSEWER 150 mm, 225 mm AND 300 mm PVC-U UNDERGROUND AND GRAVITY SEWERAGE SYSTEM, THE COMPONENTS OF WHICH ARE REFERRED TO IN THE ACCOMPANYING DETAIL SHEETS.

- The system is for use in domestic drains and public and private sewers in accordance with WIS 4-35-01 : 2000.
- The system meets the relevant conditions and standards given in Water UK/WRc plc document — Sewers for Adoption, July 2001, 5th edition.

## Regulations — Detail Sheet 1

### 1 The Building Regulations 2000 (as amended) (England and Wales)

 The Secretary of State has agreed with the British Board of Agrément the aspects of performance to be used by the BBA in assessing the compliance of drainage systems with the Building Regulations. In the opinion of the BBA, the Polysewer Gravity Sewer System, if used in accordance with the provisions of this Certificate, will meet or contribute to meeting the relevant requirements.

Requirement:	H1(1)	Foul water drainage
Comment:		The Polysewer Gravity Sewer System will convey the flow of foul or surface water and minimise the risk of blockages or leaks. See sections 6.1 and 6.2 of the relevant Detail Sheets.
Requirement:	H3	Rainwater drainage
Comment:		The Polysewer Gravity Sewer System will convey the flow of rainwater and minimise the risk of blockages or leaks. See sections 6.1 and 6.2 of the relevant Detail Sheets.
Requirement:	Regulation 7	Materials and workmanship
Comment:		The system is acceptable.

continued

continued

- Components of the system can be used individually or in combination as described in the Detail Sheets.
- This Certificate does not cover the use of the products for untreated trade effluents.

These Front Sheets must be read in conjunction with the accompanying Detail Sheets, which provide information for specific systems.

# Electronic Copy

## 2 The Building Standards (Scotland) Regulations 1990 (as amended)



In the opinion of the BBA, the Polysewer Gravity Sewer System, if used in accordance with the provisions of this Certificate, will satisfy or contribute to satisfying the various Building Regulations and related

Technical Standards as listed below.

Regulation:	10	Fitness of materials
Standard:	B2.1	Selection and use of materials, and components
Comment:		The system is acceptable.
Regulation:	24	Drainage and sanitary facilities
Standard:	M2.1	Drainage system of a building
Comment:		The system can meet the relevant requirements of this Standard. See sections 6.1 and 6.2 of the relevant Detail Sheets.

## 3 The Building Regulations (Northern Ireland) 2000



In the opinion of the BBA, the Polysewer Gravity Sewer System, if used in accordance with the provisions of this Certificate, will satisfy or contribute to satisfying the various Building Regulations as listed below.

Regulation:	B2	Fitness of materials and workmanship
Comment:		The system is acceptable.
Regulation:	N4	Underground foul drainage
Comment:		See sections 6.1 and 6.2 of the relevant Detail Sheets.
Regulation:	N5	Rain-water drainage
Comment:		See sections 6.1 and 6.2 of the relevant Detail Sheets.

## 4 Construction (Design and Management) Regulations 1994 (as amended) Construction (Design and Management) Regulations (Northern Ireland) 1995 (as amended)

Information in this Certificate may assist the client, planning supervisor, designer and contractors to address their obligations under these Regulations.

See sections: 2 *Delivery and site handling*, 3 *General* and 12 *General* of the relevant Detail Sheet.

## Conditions of Certification

### 5 Conditions

5.1 This Certificate:

- (a) relates only to the product that is described, installed, used and maintained as set out in this Certificate;
- (b) is granted only to the company, firm or person identified on the front cover — no other company, firm or person may hold or claim any entitlement to this Certificate;
- (c) has to be read, considered and used as a whole document — it may be misleading and will be incomplete to be selective;
- (d) is copyright of the BBA.

5.2 References in this Certificate to any Act of Parliament, Regulation made thereunder, Directive or Regulation of the European Union, Statutory Instrument, Code of Practice, British Standard, manufacturers' instructions or similar publication, shall be construed as references to such publication in the form in which it was current at the date of this Certificate.

5.3 This Certificate will remain valid for an unlimited period provided that the product and the manufacture and/or fabricating process(es) thereof:

- (a) are maintained at or above the levels which have been assessed and found to be satisfactory by the BBA;

(b) continue to be checked by the BBA or its agents; and

(c) are reviewed by the BBA as and when it considers appropriate.

5.4 In granting this Certificate, the BBA makes no representation as to:

- (a) the presence or absence of any patent or similar rights subsisting in the product or any other product;
- (b) the right of the Certificate holder to market, supply, install or maintain the product; and
- (c) the nature of individual installations of the product, including methods and workmanship.

5.5 Any recommendations relating to the use or installation of this product which are contained or referred to in this Certificate are the minimum standards required to be met when the product is used. They do not purport in any way to restate the requirements of the Health & Safety at Work etc Act 1974, or of any other statutory, common law or other duty which may exist at the date of this Certificate or in the future; nor is conformity with such recommendations to be taken as satisfying the requirements of the 1974 Act or of any present or future statutory, common law or other duty of care. In granting this Certificate, the BBA does not accept responsibility to any person or body for any loss or damage, including personal injury, arising as a direct or indirect result of the installation and use of this product.



In the opinion of the British Board of Agrément, the Polysewer Gravity Sewer System is fit for its intended use provided it is installed, used and maintained as set out in this Certificate. Certificate No 02/3923 is accordingly awarded to Polypipe Building Products Ltd.

On behalf of the British Board of Agrément

Date of issue: 3rd May 2002

Chief Executive

# Electronic Copy





**Polypipe Building Products Ltd**

**Certificate No 02/3923**

**DETAIL SHEET 2**

## **POLYSEWER GRAVITY SEWER SYSTEM**

### BSI Kitemarked Components

- THIS DETAIL SHEET LISTS THE COMPONENTS IN THE POLYSEWER 150 mm, 225 mm AND 300 mm GRAVITY SYSTEM THAT ARE CURRENTLY COVERED BY THE BSI KITEMARK CERTIFICATION SCHEME



*WIS 4-35-01 Specification for thermoplastic structured wall pipes, joints and couplers with a smooth bore for gavity sewers for the size range 150 to 900 inclusive.*

Kitemark certified pipe and fittings to WIS 4-35-01	Product code		
	150 mm	225 mm	300 mm
6 m plain ended pipe	PS 660	PS 1060	PS 1260
3 m plain ended pipe	PS 630	PS 1030	PS 1230
5.9 m socketed	PS 662	PS 1062	PS 1262
2.9 m socketed	PS 632	PS 1032	PS 1232
Pipe couplers	PS 601	PS 1001	PS 1201
Slip couplers	PS 600	PS 1000	PS 1200

BSI Kitemark Licence  
 No KM 55698 issued to:  
 Polypipe Ulster Ltd  
 Dromore Road  
 Lurgan  
 Craigavon  
 Co Armagh BT66 7HL



On behalf of the British Board of Agrément

Date of issue: 3rd May 2002

Chief Executive



Polypipe Building Products Ltd

**POLYSEWER 150 mm, 225 mm AND 300 mm FITTINGS**

Certificate No 02/3923

**DETAIL SHEET 3**

## Product

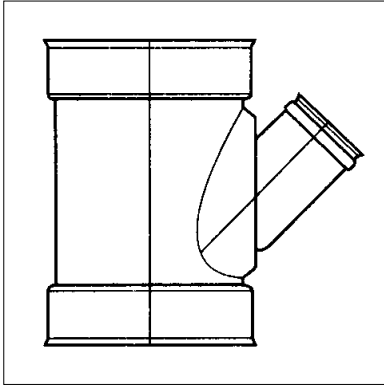

- THIS DETAIL SHEET RELATES TO THE POLYPIPE POLYSEWER 150 mm, 225 mm AND 300 mm FITTINGS.
- The Polysewer fittings are for use in domestic drains and public and private sewers at depths of up to 10 metres.

*This Detail Sheet must be read in conjunction with the Front Sheets, which give the Conditions of Certification and the product's position regarding the Building Regulations.*

## Technical Specification

### 1 Description

1.1 Polysewer fittings, where applicable, are all socketed and are either injection moulded in PVC-U or polypropylene, or thermoformed from PVC-U extruded pipe. The rodding eye is cast from aluminium. Where appropriate, the body of the fitting is ribbed (see Figure 1). The sockets of each fitting are not ribbed and have the same depth as that of pipe sockets of the corresponding diameter. The range of fittings covered by this Detail Sheet is shown in Figure 1. Rubber sealing rings are injection moulded from EPDM rubber and conform to type WC as referred to in BS EN 681-1 : 1996.

1.2 Continuous quality control is exercised during manufacture to maintain product quality and includes checks for dimensional accuracy and stress relief on the fittings.

1.3 Each fitting is embossed or labelled with the product name and code, the internal diameter and angle of bend/branch and the BBA identification mark incorporating the number of this Certificate.

### 2 Delivery and site handling

2.1 Handling, storage and transportation should be in accordance with BS 5955-6 : 1980.

2.2 When long-term storage is envisaged, the pipe, fittings and adaptors must be protected from direct sunlight.

# Electronic Copy

Figure 1 Polysewer fittings (all measurements in mm)

## Double socket bends 15°, 30°, 45° and 90°<sup>(1)</sup>



Nominal size
150 x 15°
150 x 30°
150 x 45°
150 x 90°

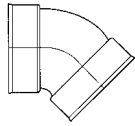

Nominal size
225 x 15°
225 x 30°
225 x 45°
225 x 90°

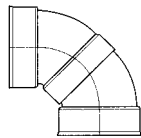

Nominal size
300 x 15°
300 x 30°
300 x 45°
300 x 90°

## Triple socket equal junctions 45° and 87½°<sup>(1)</sup>

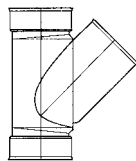

Nominal size	Nominal size
45°	87½°
150	150
225	—
300	—

## Triple socket unequal junctions 45° and 87½°<sup>(1)</sup>

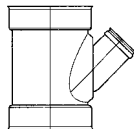

Nominal size	Nominal size
45°	87½°
150 x 110 <sup>(2)</sup>	150 x 110 <sup>(2)</sup>
225 x 110 <sup>(2)</sup>	—
225 x 150	—
225 x 160 <sup>(2)</sup>	—
300 x 110 <sup>(2)</sup>	—
300 x 150	—
150 x 160 <sup>(2)</sup>	—
300 x 225	—
300 x 160	—

## Reducers<sup>(1)</sup>

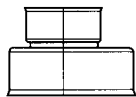

Nominal size
225 x 150
300 x 225

## Double socket adaptor to clayware pipe<sup>(1)</sup>



Nominal size
150 to super clayware pipe
150 to thick clayware pipe

## Single socket adaptor to clay socket<sup>(1)</sup>



Nominal size
225 (2 spigot)
300 (1 spigot)

## Double socket adaptor (to BS EN 1401-1 : 1998 pipe)<sup>(1)</sup>



Nominal size
150
225
300

## Single socket adaptor (to BS EN 1401-1 : 1998 socket)<sup>(1)</sup>



Nominal size
225
300

## End cap



Nominal size
150
225
300

## Socket plugs



Nominal size
150
225
300

## Rodding eye

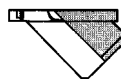

Nominal size
150 (aluminium)

## Seals

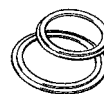

Nominal size
150
225
300

## Double socket adaptors to UltraRib pipe

Nominal size
150
225
300

## Snap cap and seal adaptors (to BS EN 1401-1 : 1998 wall pipe)

Nominal size
150 to adapt bends and 45° junctions
150 to adapt couplers and 90° junctions

(1) Seals and jointing instructions are attached to each socketed fitting.

(2) To BS EN 1401-1 : 1998.



### 3 General

The Polysewer fittings are for use as sewerage systems designed in accordance with BS EN 752-1 to 4 for the conveyance, by combined or separate systems, of surface water and domestic sewage as is permitted to be discharged into public sewers by the Water Industry Act 1991, Chapter 50, and surface water and sewage as is permitted and defined by the sewerage (Scotland) Act 1968 and the Water and Sewerage Services (Northern Ireland) Order 1973.

### 4 Strength

4.1 The fittings have adequate strength for use in situations when pipe to WIS 4-35-01 : 2000 (Issue 1) is suitable.

4.2 The nominal short-term stiffness is not less than  $8 \text{ kNm}^{-2}$ .

4.3 The nominal 50-year stiffness is not less than  $3 \text{ kNm}^{-2}$ .

### 5 Performance of joints

5.1 The performance of joints will not be adversely affected by thermal expansion or contraction when correctly made.

5.2 Joints on the pipeline remain watertight under conditions of pipeline movement in excess of those expected to occur in normal good drainage practice.

### 6 Flow characteristics

6.1 The products will have the normal flow characteristics associated with PVC-U underground sewerage systems.

6.2 Full bore velocities are available from the *Table for the Hydraulic Design of Pipes, Sewers and Channels*, Volume 2, 7th Edition by H R Wallingford and D I H Barr. The values are based on the Colebrook-White equation.

### 7 Resistance to chemicals

7.1 The products are suitable for use where pipe to WIS 4-35-01 : 2000 (Issue 1) and fittings to BS EN 1401-1 : 1998 are normally used. They have adequate resistance to the type and quantities of chemicals likely to be found in domestic sewage.

7.2 Details of the chemical resistance of PVC-U is given in CP 312-1 : 1973 and for EPDM rubber in ISO 7620 : 1986.

### 8 Resistance to elevated temperatures

The products are for use where pipe to WIS 4-35-01 : 2000 (Issue 1) and fittings to BS EN 1401-1 : 1998 are normally used and

have adequate resistance to the temperatures likely to be found in domestic sewage.

### 9 Practicability of installation

The products are installed easily under normal site conditions.

### 10 Rodding

10.1 Drains incorporating the product can be rodded easily using conventional flexible drain rods. Toothed root cutters, as used with some mechanical cleaning systems, could damage the fittings and should not be used.

10.2 The system has adequate resistance to water cleansing using pressure jetting equipment. It is recommended that low pressure, high volume systems are utilised in accordance with WIS 4-35-01 : 2000 (Issue 1).

### 11 Durability

In the opinion of the BBA, when used in the context of this Detail Sheet, no significant deterioration of the product will take place and installations will have a life in excess of 50 years.

## Installation

### 12 General

Installation must be in accordance with the *Polysewer Technical Brochure* and, when appropriate, BS 5955-6 : 1980, BS EN 752-1 to 4 : 1998 and the Water UK/WRc plc document — *Sewers for Adoption*, July 2001, 5th edition.

### 13 Jointing procedure

13.1 The pipe is cut midway between the corrugations as shown in Figure 2.

Figure 2 Joint details

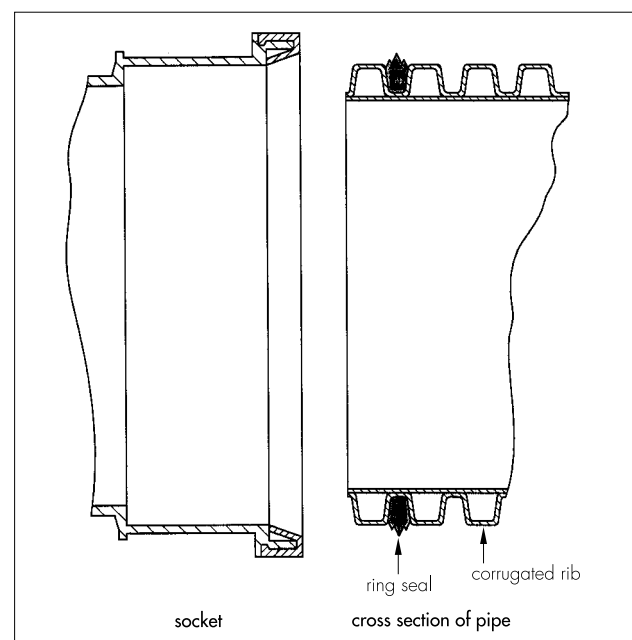

13.2 Swarf is removed from the pipe end — a chamfer is not required.

13.3 The pipe spigots and sockets are cleaned and the sealing ring is checked to ensure that it is correctly seated (not twisted) between the first and second corrugations of the pipe end.

13.4 The Certificate holder's lubricant is applied generously to the whole of the inside area of the socket and to the sealing ring, ensuring that it does not subsequently become contaminated with dirt.

13.5 The pipe is offered to the socket, the pipe aligned and pushed fully home.

13.6 Jointing to other materials must be carried out in accordance with *Polysewer Design and Installation Guide*.

13.7 The fittings must have adequate protection against damage from site traffic.

## 14 Procedure for laying pipes

**On trench bottom in granular material** (see Figure 3).

14.1 Where the as-dug material is suitable<sup>(1)</sup> for use as bedding, the bottom of the trench may be trimmed to form the pipe bed.

(1) Suitable material is defined as granular material in accordance with the recommendations of BS 5955-6 : 1980, Table 2.

14.2 Small depressions should be made to accommodate the pipe sockets or couplings. After the pipe has been laid these should be carefully filled to ensure that no voids remain under, or around, the socket.

14.3 When the formation is prepared, the pipes should be laid upon it true to line and level within the specified tolerances. Each pipe should be checked and any necessary adjustments to level made by raising or lowering the formation, ensuring that the pipes finally rest evenly on the adjusted formation throughout the length of the barrels. Adjustment should never be made by local packing.

14.4 Where the formation is low and does not provide continuous support, it should be brought up to the correct level by placing and compacting suitable material.

**On granular beds** (see Figures 3 and 4)

14.5 When the as-dug material is not suitable as a bedding, a layer of suitable granular material (see section 14.1) must be spread evenly on the trimmed trench bottom before the pipes are installed. The trench should be excavated to allow for a minimum thickness of 100 mm granular bedding under the barrels, in accordance with BS 5955-6 : 1980 (see Figure 2).

14.6 The trench formation should be prepared, the bedding placed and the pipes laid in

accordance with BS 5955-6 : 1980 and BS 8301 : 1985.

14.7 For 150 mm pipes and fittings and where the as-dug material can be hand trimmed by shovel and is not puddled when walked upon, a 50 mm depth of bedding material may be used. In this case the material must be a nominal 10 mm, single-sized aggregate with no sharp edges, ie pea gravel (see Figure 4).

14.8 When the 150 mm pipes are to be laid on rock, compacted sand or gravel requiring mechanical means of trimming, or in very soft or wet ground, the bedding should be as detailed in section 14.5.

Figure 3 Pipes laid on trench bottom

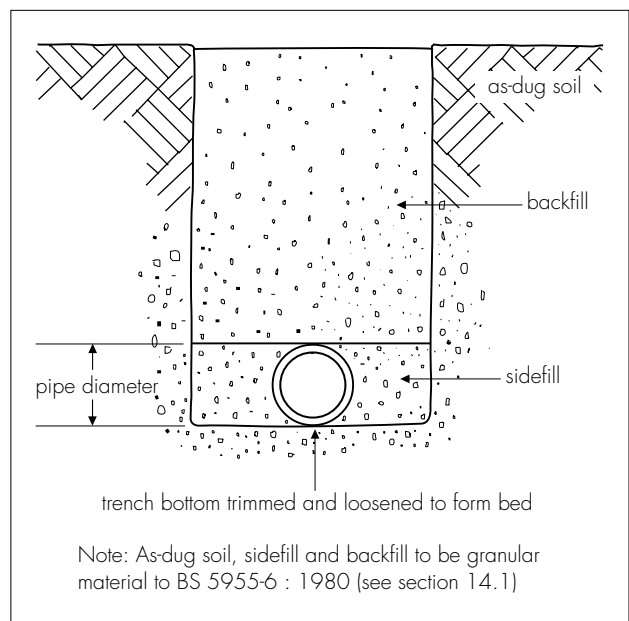

Figure 4 Pipes laid on 100 mm minimum granular bedding

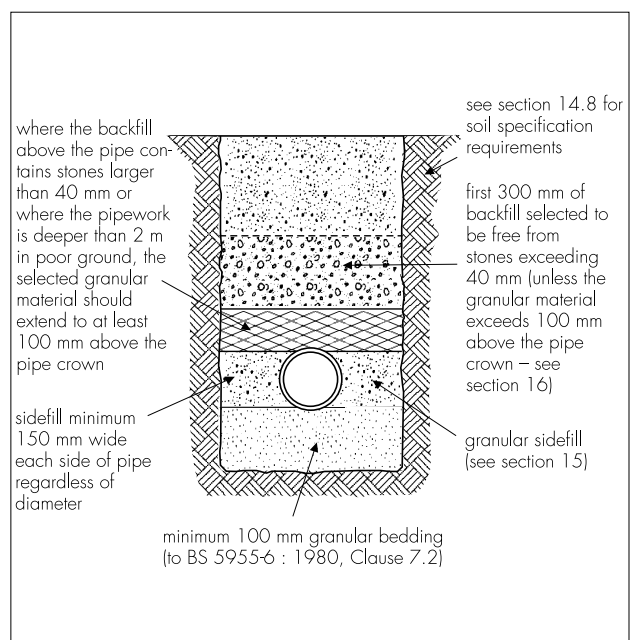
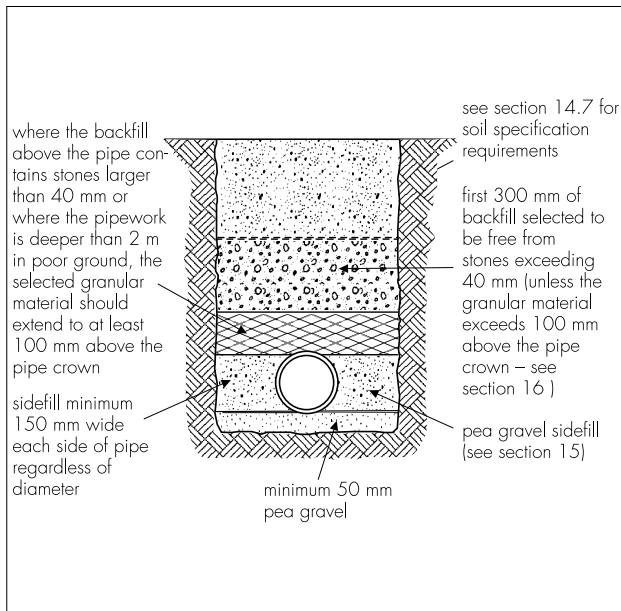

Figure 5 Pipes laid on 50 mm minimum pea gravel bedding



## 15 Sidefill

In all cases the sidefill must be of the same specification as the bedding material and extend to the level of the crown of the pipe and be placed and compacted in accordance with BS 5955-6 : 1980.

## 16 Backfill

Backfill above the level of the crown of the pipe must be in accordance with BS 5955-6 : 1980 (see Figures 3, 4 and 5).

## Technical Investigations

### 17 Tests

Tests were carried out on the system to determine:

- combined temperature and external load to WIS No 4-35-01 : 2000 (Issue 1), Appendix A
- leaktightness whilst under angular deflection and diametric distortion to WIS No 4-35-01 : 2000 (Issue 1), and BS EN 1277 : 1996
- ring flexibility to WIS No 4-35-01 : 2000 (Issue 1) and BS EN 1446 : 1996
- impact resistance to WIS No 4-35-01 : 2000 (Issue 1) and BS EN 1411 : 1996
- ring stiffness to ISO 13967 : 1998
- resistance to internal puncture to WIS No 4-35-01 : 2000 (Issue 1)
- resistance to internal pressure to WIS No 4-35-01 : 2000 (Issue 1)
- ease of jointing
- dimensional accuracy.

### 18 Other investigations

18.1 An examination was made of data relating to:

- resistance to damage before installation
- resistance to damage from sharp aggregate
- practicability of installation
- chemical resistance
- design method
- flow capacities.

18.2 A user survey was carried out to evaluate the performance of the products in use.

18.3 The manufacturing process was examined, including the methods adopted for quality control, and details were obtained of the quality and composition of the materials used.

## Bibliography

BS 4660 : 2000 *Thermoplastics ancillary fittings of nominal sizes 110 and 160 for below ground gravity drainage and sewerage*

BS 5955-6 : 1980 *Plastics pipework (thermoplastics materials) — Code of practice for the installation of unplasticized PVC pipework for gravity drains and sewers*

BS 8301 : 1985 *Code of practice for building drainage*

BS EN 681-1 : 1996 *Elastomeric seals — Material requirements for pipe joint seals used in water and drainage applications — Vulcanized rubber*

BS EN 752-1 : 1996 *Drain and sewer systems outside buildings— Generalities and definitions*

BS EN 752-2 : 1997 *Drain and sewer systems outside buildings— Performance requirements*

BS EN 752-3 : 1997 *Drain and sewer systems outside buildings— Planning*

BS EN 752-4 : 1998 *Drain and sewer systems outside buildings— Hydraulic design and environmental considerations*

BS EN 1277 : 1996 *Plastics piping systems — Thermoplastics piping systems for buried non-pressure applications — Test methods for leaktightness of elastomeric sealing ring type joints*

BS EN 1401-1 : 1998 *Plastics piping systems for non-pressure underground drainage and sewerage. Unplasticized poly(vinylchloride) (PVC-U) — Specifications for pipes, fittings and the system*

BS EN 1411 : 1996 *Plastics piping and ducting systems — Thermoplastics pipes — Determination of resistance to external blows by the staircase method*

BS EN 1446 : 1996 *Plastics piping and ducting systems. Thermoplastics pipes — Determination of ring flexibility*

CP 312-1 : 1973 *Code of practice for plastics pipework (thermoplastics material) — General principles and choice of material*

ISO 7620 : 1986 *Rubber materials — Chemical resistance*

ISO 13967 : 1998 *Thermoplastics fittings — Determination of ring stiffness*

WIS 4-35-01 : 2000 (Issue 1) *Specification for thermoplastic structured wall pipes, joints and couplers with a smooth bore for gravity sewers for the size range 150 to 900 inclusive*



On behalf of the British Board of Agrément

Date of issue: 3rd May 2002

A handwritten signature in black ink, appearing to read 'P. C. Hewson'.

Chief Executive



# Electronic Copy

