

Within this bulletin we will talk about our WC manifold connector and how the different angles are used to create a WC float of up to 7 WC's.

It is possible to install a corner or double branch and have two floats of 7 WCs flowing into each branch. There are 4 standard angles available and 3 fabricated angles available within our range, but can also fabricate unique angles for those unusual situations.

When used in conjunction with a branch 104, up to 7 WC pans can be connected either side of the soil stack.

WC Manifold Connectors Fin Seal Spigot				
Size (mm)	Angle	Colour	Pack/Box	Terrain Part Code
110	5	W	-/6	499.4.05
110	14	W	-/6	499.4.14
110	24	W	-/6	499.4.24
110	34	W	-/6	499.4.34
110	9	W	-/1	S499.4.09
110	18	W	-/1	S499.4.18
110	29	W	-/1	S499.4.29
110	†	W	-/1	S499.4.X

†Customer to specify angle on order



We also have a range of WC manifolds which are designed to be connected straight onto WC frames for wall hung pans. These are installed exactly the same as the WC manifold but are clipped into place on the WC frame.

WC Manifold Bend Connectors Fin Seal Spigot				
Size (mm)	Angle	Colour	Pack/Box	Terrain Part Code
110	5	B	5/10	497.35.05
110	14	B	5/10	497.35.14
110	24	B	5/10	497.35.24
110	34	B	5/10	497.35.34
110	9	B	1/24	F497.35.09
110	18	B	1/12	F497.35.18
110	29	B	1/12	F497.35.29



WC Connections - HDPE FUZE

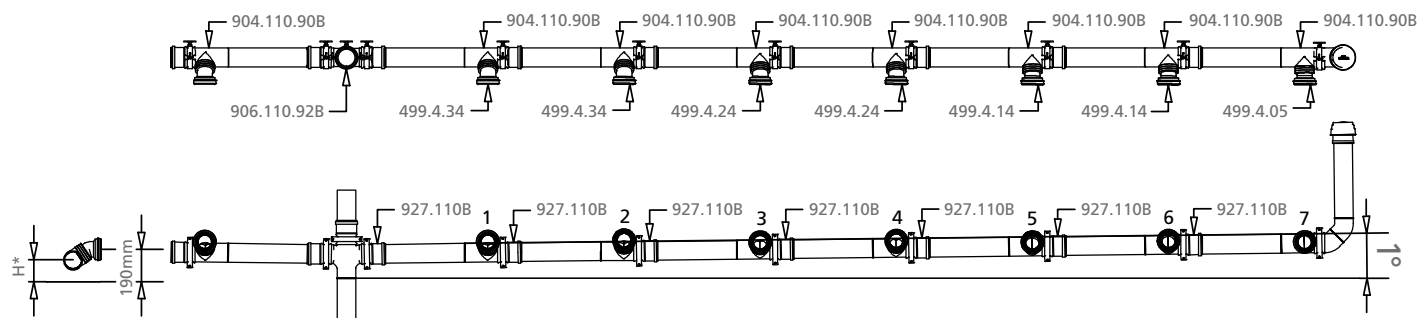

Float laid to a Fall of 1° (17mm drop/1 metre run)

Note: If a secondary ventilation system is being installed then expansion must be provided to both the soil and waste stack and the secondary ventilation stack.

Note: It is important to lubricate the ring seal adaptor with silicone grease. (9136.250L)

Branch Height (Height H* from FFL)							
H*	1	2	3	4	5	6	7
mm	86	100	114	128	142	156	170

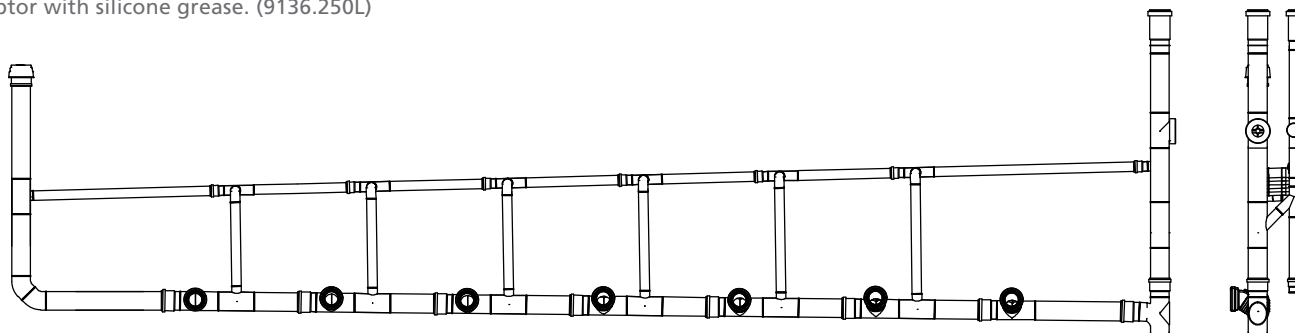

Risers and Branches

It is recommended that an expansion socket is incorporated at each floor level when designing and installing HDPE FUZE stacks in multi-storey buildings.

Where a branch is taken off a main run, the thermal movement of the main run is going to affect the branch.

- Establish the distance between the branch and the nearest anchor.
- Calculate the movement at the point where the branch joins the run.

- Establish the hole size through the wall and ensure that there is enough space for the branch to naturally flex, taking into account that the movement of the branch will be limited where it passes through a wall.
- If there is not enough room for the required offset, think about adding expansion sockets and anchor points to the main run to reduce the amount of movement experienced by the branch.

WC Connections - PVC

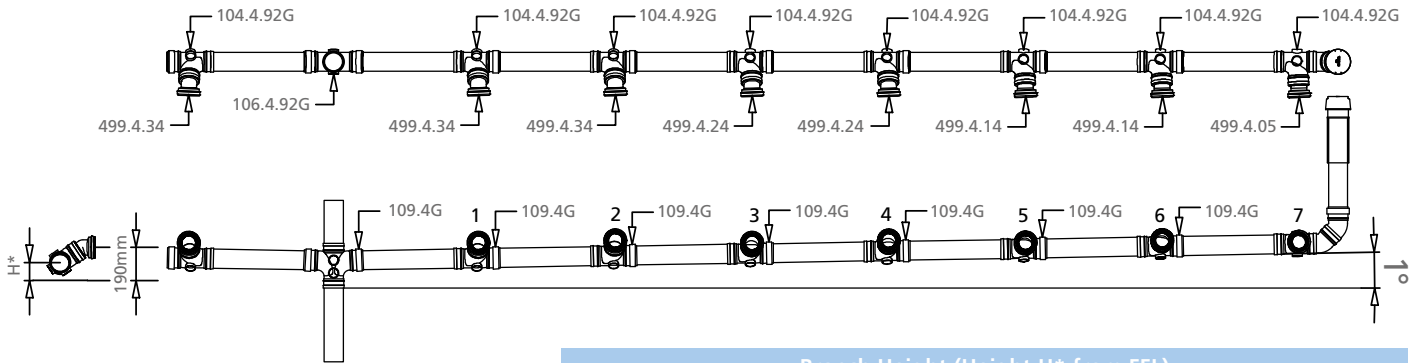

Float laid to a Fall of 1° (17mm drop/1 metre run)

Note: If a secondary ventilation system is being installed then expansion must be provided to both the soil and waste stack and the secondary ventilation stack.

Branch Height (Height H* from FFL)							
H*	1	2	3	4	5	6	7
mm	86	100	114	128	142	156	170

Note: It is important to lubricate the ring seal adaptor with silicone grease. (9136.250L)

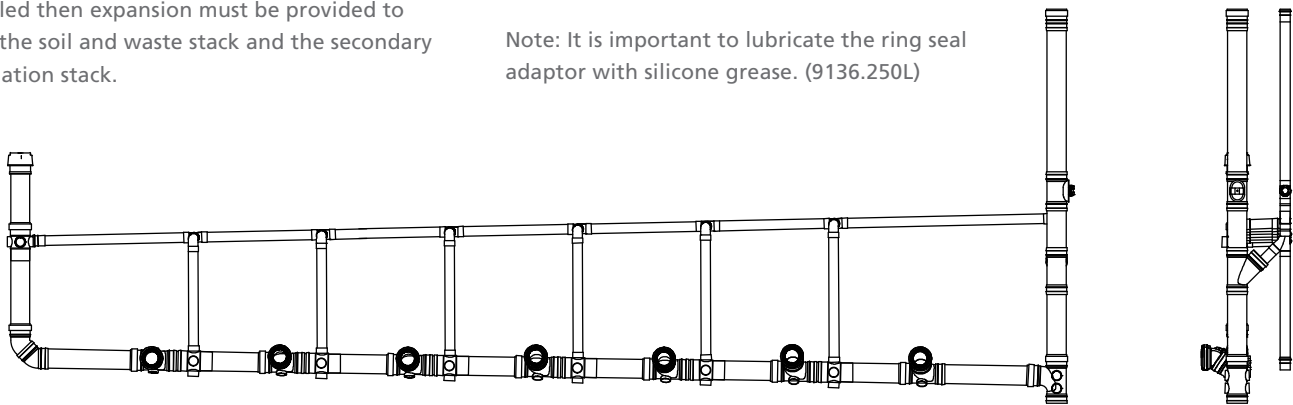

Risers and Branches

It is recommended that an expansion socket is incorporated at each floor level when designing and installing 100 Series PVC stacks in multi-storey buildings.

Where a branch is taken off a main run, the thermal movement of the main run is going to affect the branch.

- Establish the distance between the branch and the nearest anchor.
- Calculate the movement at the point where the branch joins the run.

- Establish the hole size through the wall and ensure that there is enough space for the branch to naturally flex, taking into account that the movement of the branch will be limited where it passes through a wall.
- If there is not enough room for the required offset, think about adding expansion sockets and anchor points to the main run to reduce the amount of movement experienced by the branch.



Contact Us

to find out about our Technical Workshop

Next month's
Technical Bulletin -
4 Way Boss