

Live Stack Replacement

As momentum continues to build behind the UK construction industry, focus is often on new build projects. However, to meet the increasing demands of the growing UK economy, attention must also be given to replacement and refurbishment projects.

This Technical Bulletin will focus on the benefits of using Terrain Fabricated Drainage Stacks when replacing existing stacks within buildings that are already occupied. This process, known as "Live Stack Replacement", can lead to significant pressure on contractors as the time a system can be shut down must be limited. This bulletin will detail the process of "Live Stack Replacement" at a social housing project in Birmingham, where 110mm soil and 75mm waste stacks were being replaced.

For the site to benefit from Terrain Fabricated Drainage Stacks initially an enquiry was received by the Terrain Technical Office. From this enquiry, the site requirements were clarified and draft stack drawings were supplied to the client. Following some amendments, the drawings were signed off by the client and orders for the stacks were placed. From time of order, stacks have been produced to meet the timescales demanded by the client. The factory assembled stacks have been manufactured in both Terrain FUZE HDPE and Terrain dB12 products and delivered to site for installation. For added piece of mind all Terrain Fabricated Drainage Stacks can be tested in our Fabrication Department to ensure a reliable leak tight stack, leaving the client to only test connections made on site, such testing is available upon request.

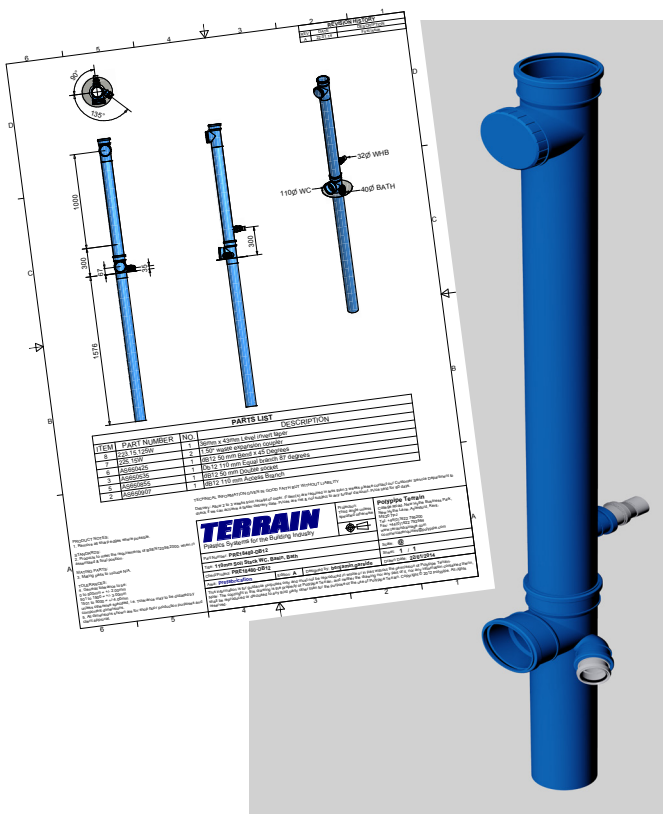

dB12 Stack Drawing and Fabricated Stack

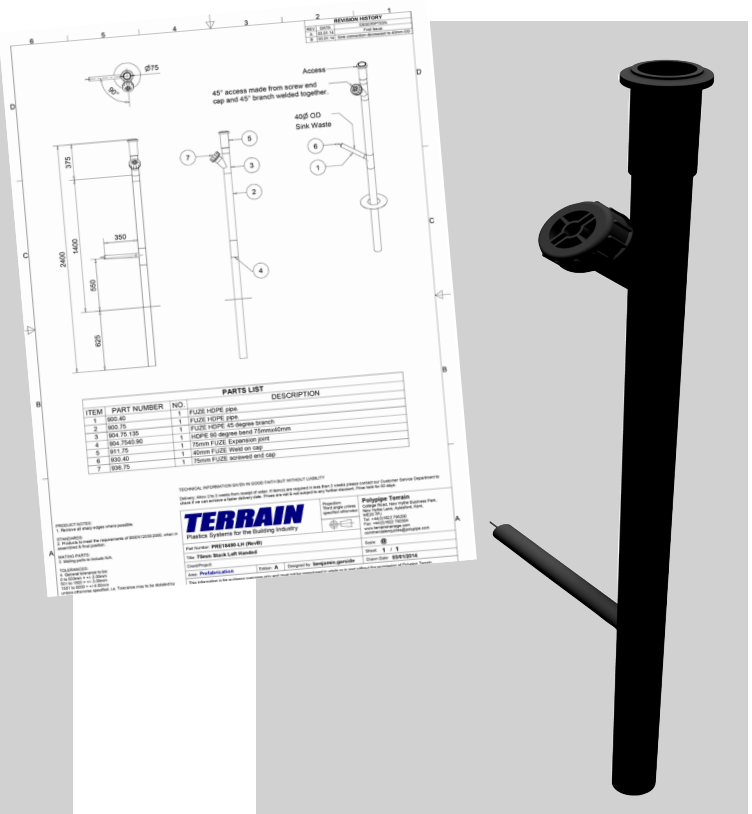

FUZE Stack Drawing and Fabricated Stack

Live Stack Replacement

On-site Installation:

The client's plan of work has been detailed to the most exacting time, to ensure that disruption to residents has been minimised, key to this has been the delivery and installation time of the Terrain Fabricated Drainage Stacks. Once on-site the time to remove the existing stack, including removal of appliances and duct work, and installation of the new Terrain Fabricated Drainage Stacks is circa 3 hours. Compare this to the assembly time required of standard pipe and fittings and subsequent installation of 5 hours indicates approximate on site time savings in the region of 40%. In addition to these time savings many stack replacements are made more difficult by poor access and space within risers. Terrain Fabricated Drainage Stacks are of further benefit because they can be manufactured under controlled factory conditions to incorporate special connections and unique fittings to overcome on-site issues.

The table below indicates the number of joints, number of cuts and installation time of the Terrain FUZE and Terrain dB12 Fabricated Drainage Stacks v the number of fittings, joints required for installation/ commissioning, and time to install for standard Terrain FUZE and Terrain dB12 pipe and fittings. For each Terrain Fabricated Drainage Stack the number of "Unique" features is also indicated, i.e. without these features the installation would be difficult and more labour intensive due to on-site restrictions.

	Terrain dB12 Fabricated Stack	Terrain FUZE Fabricated Stack	On-Site Assembled dB12 stack	On-Site Assembled FUZE stack
Number of Joints	5	3	12	9
Number of cuts	1	2	2	3
Installation Time	3 hours	3 hours	5 hours	5 hours
Number of fittings	1 (complete stack supplied)	1 (complete stack supplied)	9	7
Unique features*	3	1	N/A	N/A

*Unique features relates to the ability to create on-site the same stack from standard pipe and fittings without the need for specialized on-site fabrications to enable installation.

This bulletin has indicated, for a specific project, the benefits of using Terrain Fabricated stacks vs on-site assembly and installation. The clear and measurable benefit is the 40% time saving for installation, essential when having to manage not only the expectations of the building owner but also the needs of residents. The use of Terrain Fabricated Stacks also enables simple "Live Stack Replacement" to take place whatever the in-situ material as all requirements are designed in prior to manufacture, often this is not possible with standard pipe and fittings. Specifically for the project in Birmingham it would simply not have been possible to create the soil stack on-site from standard fittings to enable the "Live Stack Replacement" approach to be successful.

Finally, sites are increasingly under pressure to reduce waste. The use of Terrain Fabricated Drainage Stacks will significantly reduce the waste generated due to the stacks being designed for a specific project. Additionally as stacks are delivered to site without the need for additional packaging, sites will also see a reduction in the amount of cardboard waste generated.

To find out more about the Terrain Fabrication Service and to discuss your own requirements please contact me at steve.bishop@polypipe.com