

Terrain PVCu and MuPVC pipe work systems expand with changes in temperature, both ambient temperature and from the temperature of the waste discharge through the pipework.

This technical bulletin will describe the principals of expansion design and provides advice covering assembly and jointing techniques. The advice and guidance is based on typical situations only. For further information, refer to the Terrain soil and waste installation guide or contact the Terrain Technical Services Department.

Design

Terrain PVCu has a significant coefficient of expansion, 0.04 (mm/m/°C), the design and installation of above ground drainage systems must be able to accommodate this expansion. Expansion joints should be used at the following maximum distances.

Pipe size (mm)	Maximum Distance between expansion joint (m)
Pipe size - soil	
82	4.0
110	4.0
160	4.0
Pipe size - waste	
32	2.0
40	2.0
50	2.0

Support and Expansion Distances

Unless there is an alternative provision for thermal movement, pipework should be fitted with expansion joints in the following locations:

- a) At spacings no greater than 4m for pipework 82mm and above.

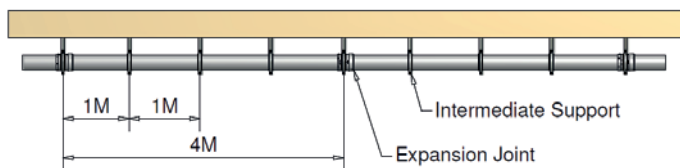

- c) Where the maximum distance between fixed points exceeds 1m.

- b) At spacings no greater than 2m for pipework 50mm and below.

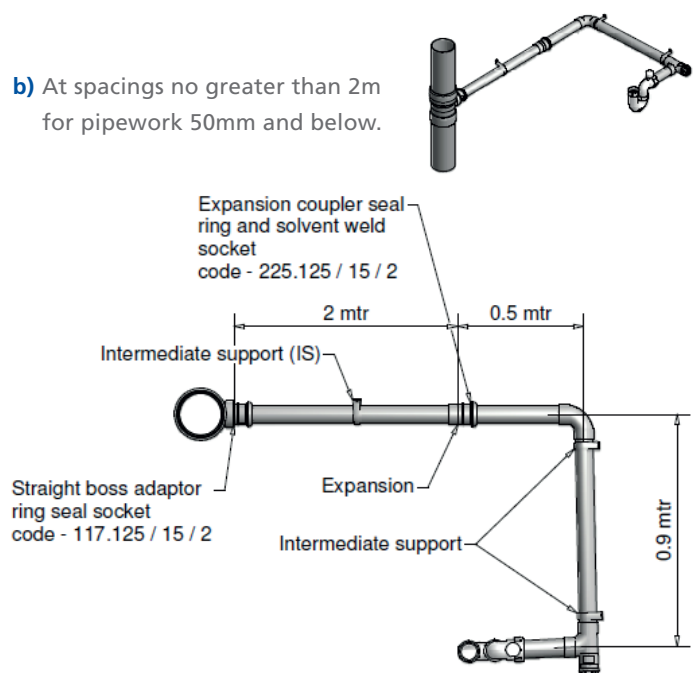

d) Any point where pipework passes through a floor or wall and is made good or fire stopped must be treated as a fixed point when determining positions of expansion joints.

Figure 2. Expansion joints and fixed points.

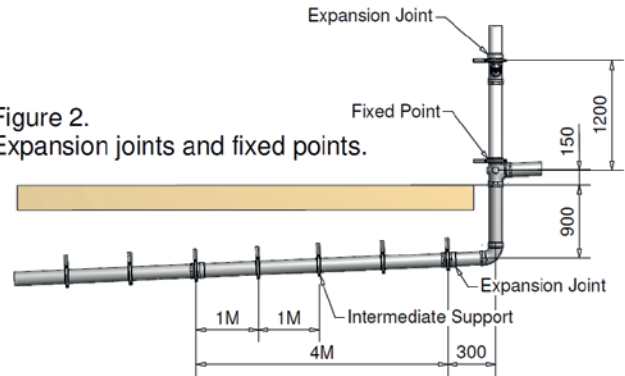

Float laid to a Fall of 1° (17mm drop/1 metre run).

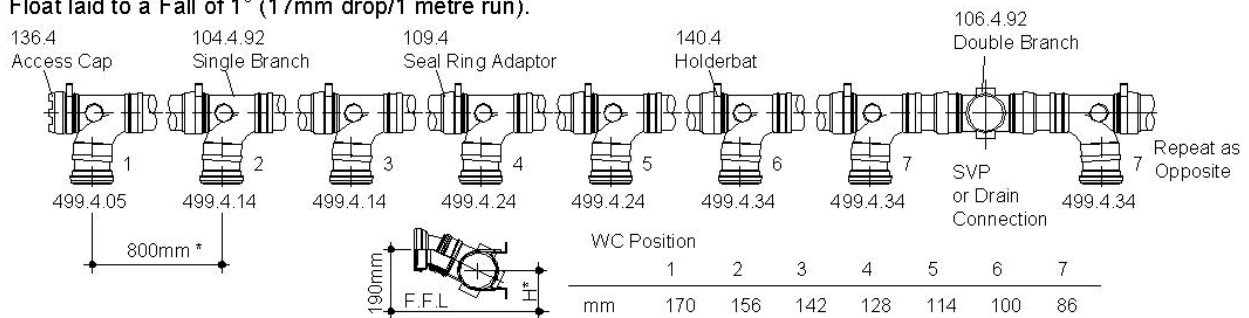

* For centres less or greater than 800mm see overleaf or contact our Technical department on Maidstone (01622) 795200.

e) Low level WC manifolds incorporate ring seal adaptors at each branch connection to compensate for expansion and also allow the branch to be 'turned' to the correct angle to allow connection to the WC.

Note:

If a secondary ventilation system is being installed then expansion must be provided to both the soil and waste stack and the secondary ventilation stack.

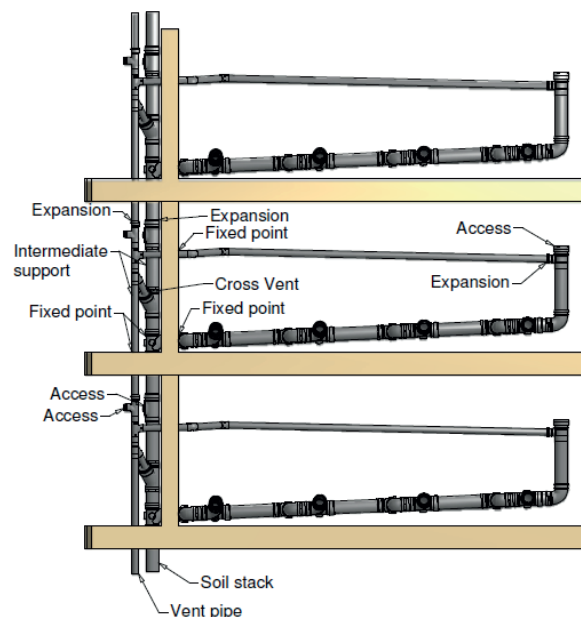

Expansion Joints

Pipe brackets must be used to anchor expansion joints. The anchor point can be made directly in the bracket grooves provided on pipework fittings or alternatively directly onto the pipe.

When anchoring the pipework using a solvent weld fitting, a ring seal adaptor (code 109) needs to be solvent welded to the fitting to accommodate expansion. It is important to lubricate the ring seal adaptor with silicone grease (9136.250L).



The pipe connecting into the ring seal adaptor should be inserted fully into the socket and marked. To create the expansion gap withdraw the pipe 12mm from the socket. This gap will allow the pipe to expand sufficiently without distorting the pipework.

Anchor points directly onto the pipe can be made using a solvent welded piece (code 9104). The anchor point must be within one metre of the proposed point of anchorage.

Note: On internal pipework systems subject to fire requirements it is recommended that only steel support brackets (code 140) are installed. Intermediate support must also be provided.

Pipework supports shall be provided in accordance with the following tables and either side of bends.

Pipe Material	Pipe Size (mm)	Vertical Pipes (m)	Low Gradient Pipes
MuPVC	32-40	1.2	0.5
	50	1.2	0.9
PVC-u	82-110	2.0	1.0
	160	2.0	1.0

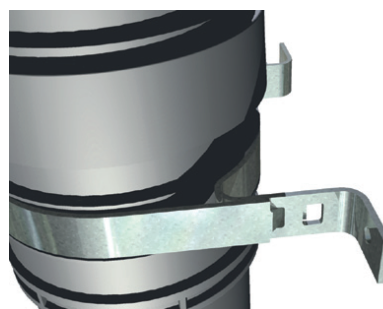

Multiple pipe supports for pipes of differing sizes shall be spaced at intervals required for the smallest pipe.

The Thermal Movement Limiter (TML - code 190) prevents the pipe from pulling out of the ring seal adaptor and causing a leak. It will also be necessary to install an intermediate support bracket (code 191).

On relatively short horizontal suspended runs, expansion can be accommodated using a ring seal adaptor (code 109).



On longer suspended runs, expansion joints should be made using a TML (code 190).



It is also recommended that cross bracing is incorporated where branches enter a main run, the bracing is necessary to stabilise the pipework.



Alternative Provision for Thermal Movement

Expansion joints may be omitted if alternative provision is created in one of the following ways.

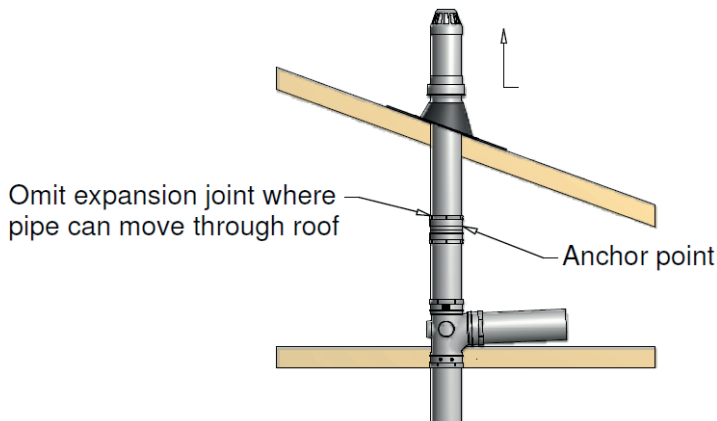

- a) Above the highest branch connection to a foul and/or waste stack is free to move through a weather proof roof sleeve.

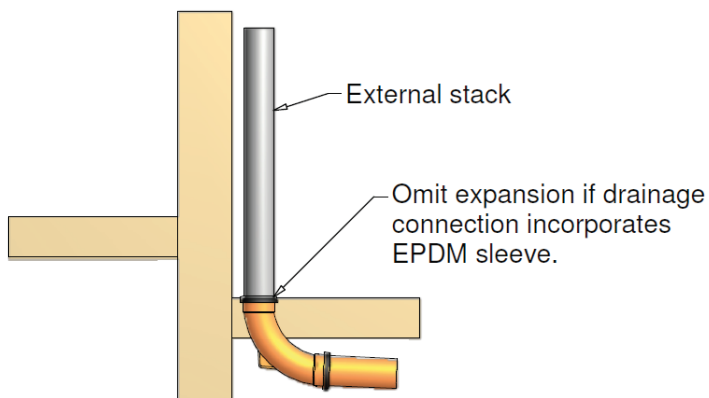

- b) At the base of an external drainage stack that is connected to a drainage connection that allows movement through an EPDM sleeve.

Risers and Branches

It is recommended that an expansion joint is incorporated at each floor level when designing and installing PVCu stacks in multi-storey buildings.

Where a branch is taken off a main run, the expansion movement of the main run is going to affect the branch.

- a) Establish the distance between the branch and the nearest anchor
- b) Calculate the movement at the point where the branch joins the main run
- c) Establish the hole size through the wall and ensure that there is enough space for the branch to naturally flex, taking into account that the movement of the branch will be limited where it passes through a wall
- d) If there is not enough room for the required offset, think about adding expansion joints and anchor points to the main run to reduce the amount of movement experienced by the branch

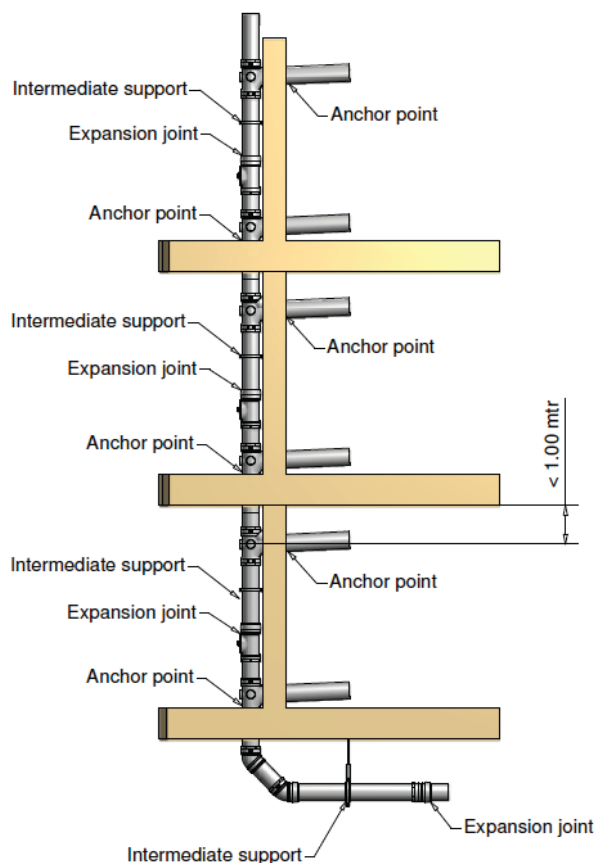

Contact Us

to find out about our Technical Workshop

Next month's
bulletin will be
on bracketry
within pressure
systems